

A-21-U Strap Tie

2,250 lbs.
Safe Working Load

Dayton/Richmond A-21-U Strap Tie is used to align, tie and secure steel frame form panels. Ties are available for wall thickness of 6" through 24" in 1/2" increments. The wall thickness is stamped on each tie. Standard breakback for A-21-U ties is 1/2".

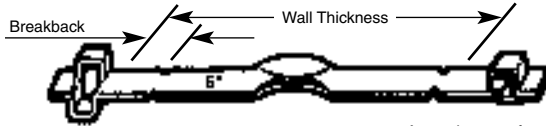

Approximate safety factor 2:1

A-21-X Flat Tie

3,000 lbs.
Safe Working Load

Dayton/Richmond A-21-X Flat Tie is used with the A-51 Wedge Bolt to secure and space modular forms. A-21-X ties are available in 6" through 24" in 1/2" increments. The wall thickness is stamped on each tie. Standard breakback is 1/4".

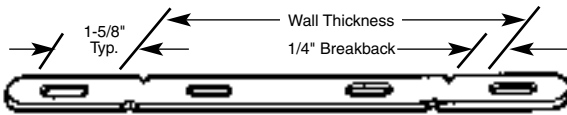

Approximate safety factor 2:1

A-46 Loop Panel Tie, Standard and Heavy

Dayton/Richmond A-46 Loop Panel Ties are designed for securing and spacing modular type forms. Standard units are fabricated with 2-1/8" ends and 1" breakback. Other breakbacks, plastic cones or waterseal washers are available on special order.

When erecting modular type forms, the A-46 ties are placed in the slots between the form panels. An A-51 Wedge Bolt is placed through the adjoining form and into the loop of each tie. A second wedge bolt is then placed through the slot of the first wedge bolt to secure the tie and form together.

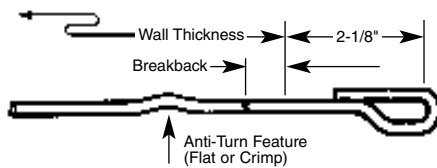

2,250 lbs.
(Standard Ties)
3,000 lbs.
(Heavy Ties)
Safe Working Load

Approximate safety factor 2:1

A-48 Gang Loop Tie, Standard and Heavy

Dayton/Richmond A-48 Gang Loop Tie is similar to the A-46 tie, above, but has end dimensions extended to 4-15/16". The longer length allows the tie to be used with gang form bolts (supplied by others) and to be broken back before the form has been stripped. 1" breakback is standard. Other breakbacks, plastic cones and/or waterseal washers are available on special order.

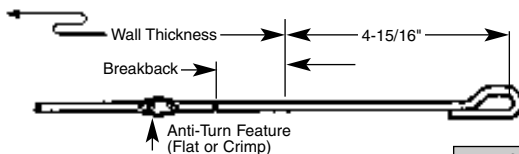

2,250 lbs.
(Standard Ties)
3,000 lbs.
(Heavy Ties)
Safe Working Load

Approximate safety factor 2:1

A-27 and A-27-M Turnbuckle Form Aligners

Dayton/Richmond A-27 and A-27-M Turnbuckle Form Aligners are designed to accurately position and plumb vertical forms. The turnbuckle section of the aligner features a 1" diameter self-cleaning coil thread for fast adjustments. Overall length of the aligner is 37" minimum and 40" maximum, offering 3" of effective adjustment.

The A-27 aligner has bent nailing plate equipped with nail holes and a 15/16" hole to accept 3/4" or 7/8" steel stakes. The A-27-M aligner has a special attachment plate that allows direct attachment to modular type forms. Both models are rugged units that offer high reuse and labor savings. The safe working load of the aligners is limited by the lumber, nailing and/or staking methods.

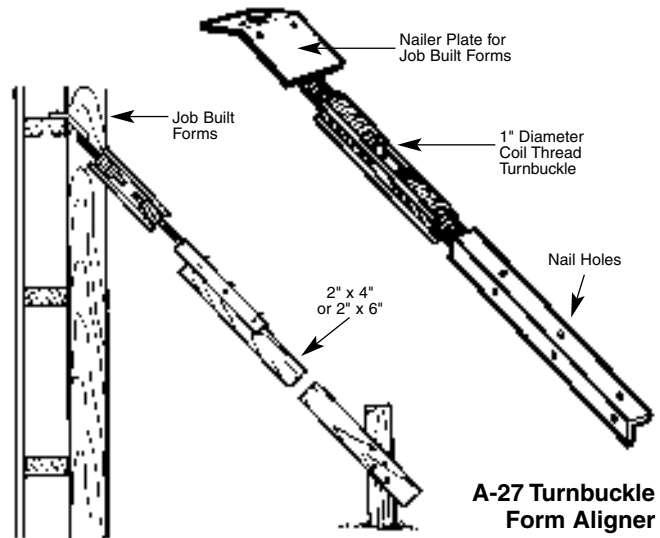

A-27 Turnbuckle Form Aligner

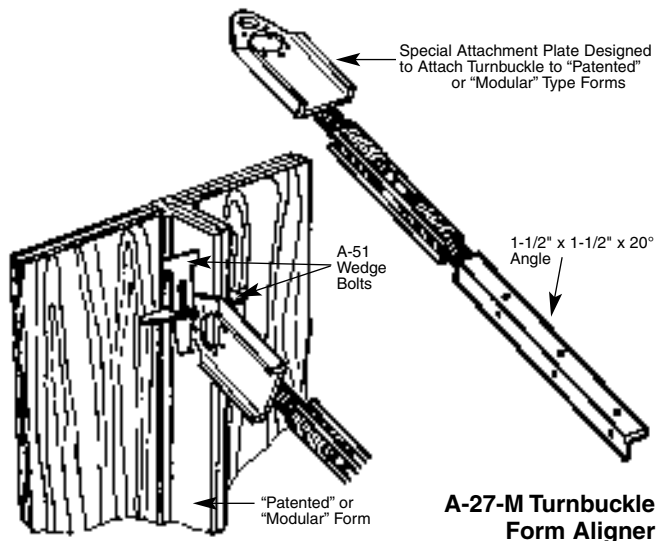

A-27-M Turnbuckle Form Aligner

A-51 Wedge Bolt

Dayton/Richmond A-51 Wedge Bolt is used with A-46 Loop Panel Ties, B-21 Plylags, etc., to secure modular type forms.

3,750 lbs.
Safe Working Load

Approximate safety factor 2:1

